

XTC2 Two Bike Rail Rack

ITEM: 64670
Page 1 of 2

INSTRUCTIONS:

1. Unfold the two side arms as shown (diagram 1) and insert the lynch pins. Ensure that the pins are all the way in.
2. Slide the 4 wheel holder trays on to the bottom arms alternating the direction of the trays (diagram 2). Do not tighten them at this time, as they will have to be adjusted to fit each bike that you are carrying.
3. Slide the hooks onto the upright portion alternating the direction (diagram 2).
4. Insert the square receiver bar into the 1-1/4" square section at the bottom of the rack (diagram 2).
5. Tighten the two set-screws to secure the receiver bar tight against the square section. Check the set-screws periodically to ensure they are tight (diagram 4).
6. Now take the whole assembly and install on the vehicle and insert the threaded pin and clip.
7. If the rack is to be used on 1-1/4" receiver you will need to remove the two Allen Bolts that hold on the spacers (diagram 5).

BIKE INSTALLATION:

1. Pull the pin on the bottom of the upright arm and fold down. This allows you to easily put the inside bike onto the rack (diagram 3).
2. Adjust the trays to the wheels of the bike so that they are all the way in the tray. Once these are adjusted tighten the knobs on the tray so that they are secure and cannot slide.
3. Fold the upright bar back into the upright position and insert the pin.
4. Push the hook down onto the bike. Press the red button below the hook to slide it more easily into place. Release the red button when the hook is securely holding the bike. Releasing the button locks the hook in place and prevents it from any upward movement while in transit.
5. Install the outside bike in the same manner.

**After complete installation check all pins and tighten knobs to ensure they are all tight and that the bikes are motionless on the rack.*

Diagram 1

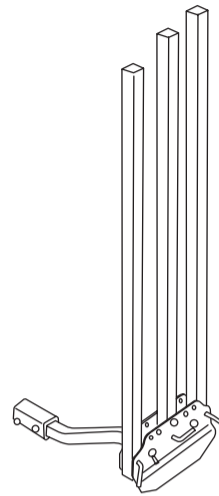

Diagram 2

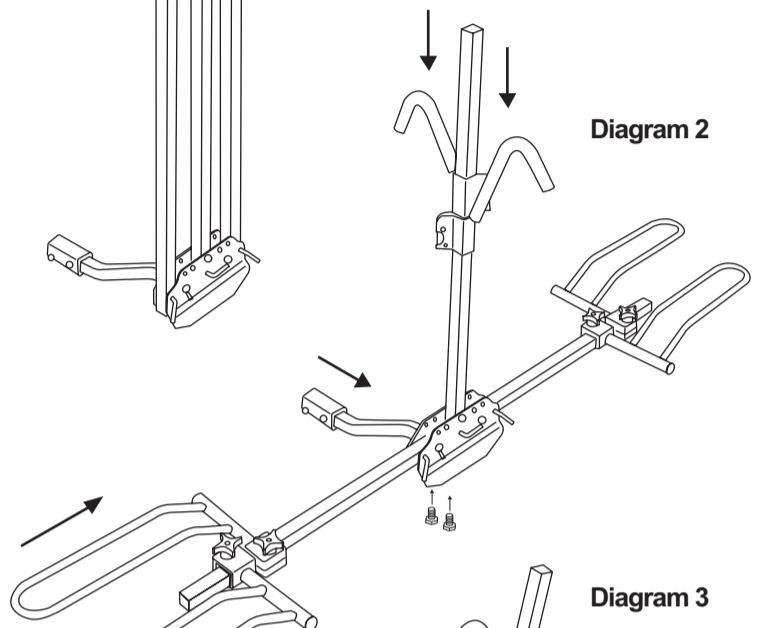

Diagram 3

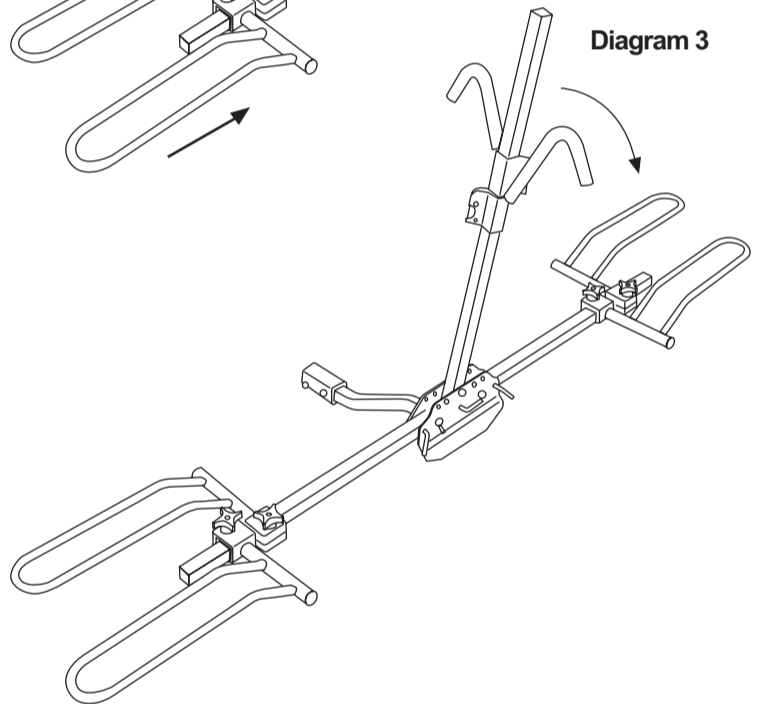

Diagram 4

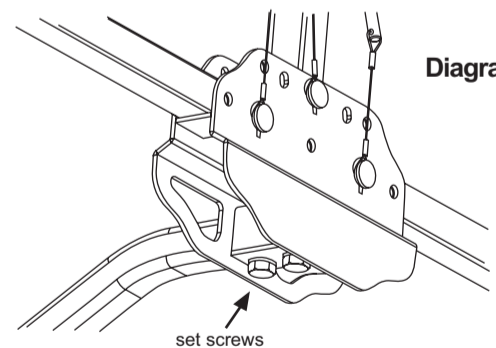
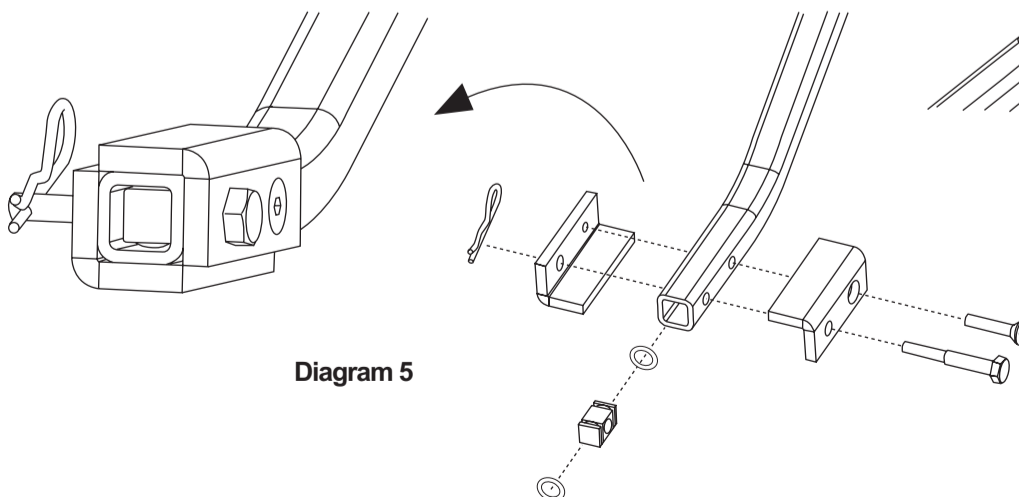

Diagram 5



XTC2

Two Bike Rail Rack



ITEM: 64670
Page 2 of 2

IMPORTANT NOTES:

1. This bicycle rack has been designed to carry 1 or 2 bikes.
2. This rack is designed for typical use and applications (on paved or smooth gravel roads). Do not use this rack on a vehicle that will be driven on rough roads or where the rack (and bikes) will be subject to significant or constant jarring and/or shock, or any vehicle with very stiff springs that will transfer the load shock directly to the rack and bikes.
3. Proper fitting and installation of this carrier to your specific vehicle is critical, and is not the manufacturer's responsibility.
4. Improper use of this product may result in damage to your rack, your vehicle, your bicycles, or even other vehicles driving behind you (as a result of colliding with or trying to avoid fallen bicycles and/or the rack).
5. The purchaser should be aware that the load created by a rack and bicycles can exceed the maximum rating on the hitch or bumper.
6. Swagman Racks are powder coated to help prevent rust. When leaving them outside for extended periods of time the finish will lose its luster. It is recommended that when not in use it is stored indoors.
7. Take care to add padding on any area of the bikes that touches another bike or any part of the vehicle. Damage can and will happen (to your bikes and/or to the vehicle) if care is not taken during the loading and transporting of your bikes, and padding used where necessary.
8. Bicycle tires should be kept at least 6" away from the exhaust pipes of the vehicle. The high temperature exhaust exiting from the exhaust pipes is hot enough to melt or damage tires. Keep all bike tires totally away from the direct exhaust flow.
9. Bikes fitted with large accessories (such as a child carrying seat) will greatly increase the wind resistance and therefore the pressure on the rack and all vehicle mounting points. Reducing vehicle speed will reduce the chance of any problems occurring because of this situation.
10. After reading this manual, should you have any additional questions regarding the compatibility, fitting, and/or use of this rack, please call your nearest Swagman authorized retail dealer or Swagman Customer Service.

Mounting the Bike Rack on a trailer or 5th wheel:

1. *Purchaser is advised that the load created by rack and bicycles may exceed the strength of trailer or 5th wheel bumper or other mounting location. Failure through improper mounting will void rack warranty.*
2. *The recommended 14" ground clearance is not sufficient on trailers or 5th wheels. Ground clearance must exceed 15" and will vary upon application. Damage to bicycles or rack due to ground clearance problems on trailers or 5th wheels is not covered by warranty.*